



L12V60UNV-A

12 Volt 60 Watt Class 2 LED Driver

- Universal input voltage 120 – 277 Vac
- Damp and Dry Location Rated
- 60W Class 2 Output



Performance

| | |
|------------------------|----------------------------------|
| Input Voltage | 120 ~ 277 Vac |
| Input Current Max | 0.58A @ 120Vac 0.26A @ 277Vac |
| Input Power Max | 69W |
| Input Frequency | 50 - 60 (Hz) |
| Power Factor | > 0.90 @ max load |
| THD Max | < 10% @ max load |
| Efficiency @ Full Load | > 86% @120Vac > 87% @277Vac |
| Output Voltage | 12V |
| Output Current | 5.0A |
| Output Power | 60W |
| Load Regulation | ±10 % |
| Output Voltage Ripple | < 1000mVp-p |
| Output Current Ripple | < 500mA p-p |
| Inrush Current | 120V: 19A / 318uS |
| Peak / >50% Duration | 277V: 47A / 306uS |

Physical

| | |
|------------------|--------------------|
| Length | 9.50 in (241.3 mm) |
| Width | 1.71 in (43.4 mm) |
| Height | 1.18 in (30.0 mm) |
| Mounting Length | 8.90 in (226.1 mm) |
| Weight (lbs) | 1.7 |
| Lead Lengths | |
| Blk, Wht | 12.5 in (317 mm) |
| Red(+), Black(-) | 12.5 in (317 mm) |

Environmental

| | |
|-----------------------|---|
| EMI and RFI | Meets FCC part 15 (Class A) Non-Consumer Limits |
| Operating Temperature | -40°C to 57°C (-40°F to 134°F) |
| Storage Temperature | -40°C to 80°C (-40°F to 176°F) |
| tc | 80°C (176°F) max |
| Protection Rating | UL Dry & Damp |
| Transient Protection | IEEE C62.41 2.5kV |

Wiring Diagram:

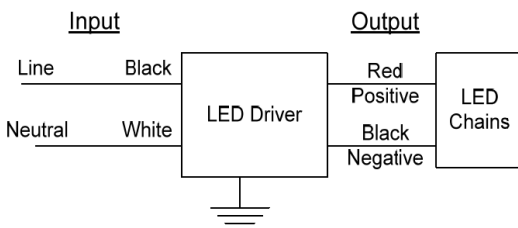

Protection:

Over Voltage, Under Voltage, Short Circuit, Over Temp

Safety:

UL 8750 & CSA 250.13-17

UL Class P



Ordering Information

| Order Number | Description | Qty/Carton |
|-----------------|-------------|------------|
| L12V60UNV-A000I | 12V 5.0A | 1 |
| L12V60UNV-A000C | 12V 5.0A | 10 |



Application and operation performance specification information subject to change without notification.



Performance: Efficiency

Typical performance measurements are shown. The charts are to be used as a guideline and not for specification use.

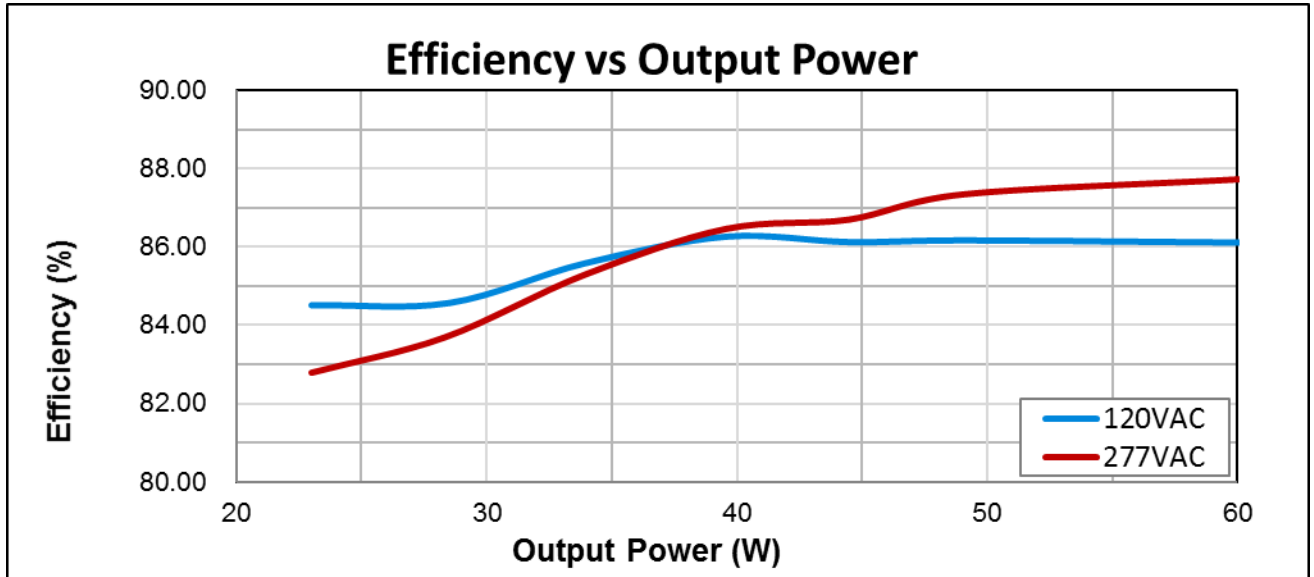

Application and operation performance specification information subject to change without notification.



Performance: Total Harmonic Distortion, & Power Factor

Typical performance measurements are shown. The charts are to be used as a guideline and not for specification use.

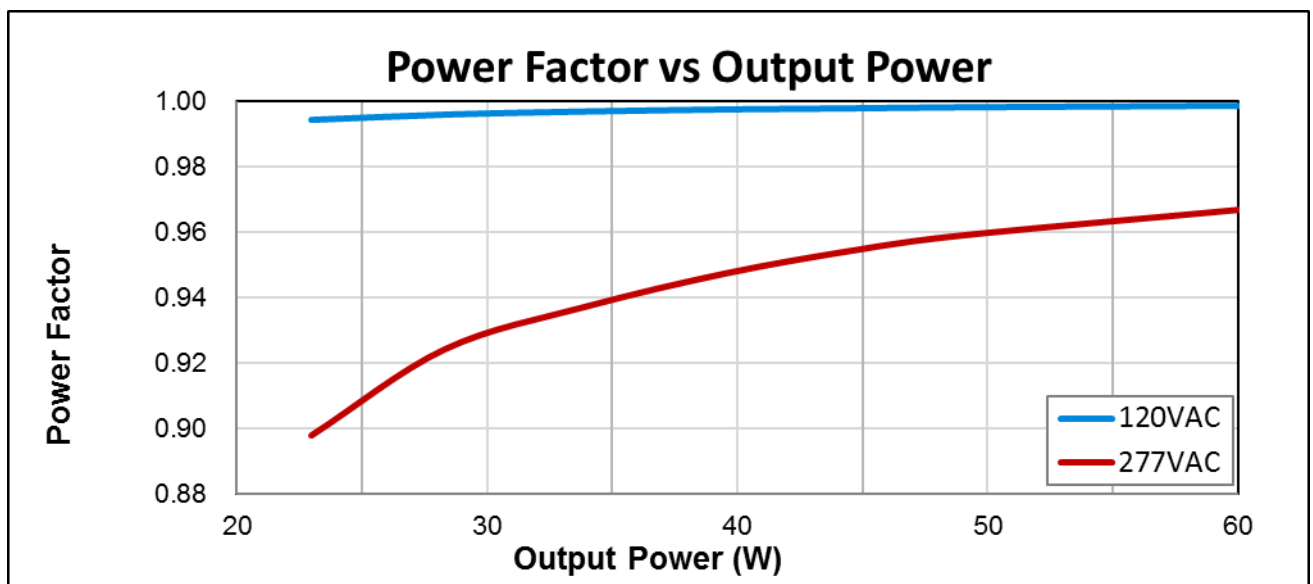
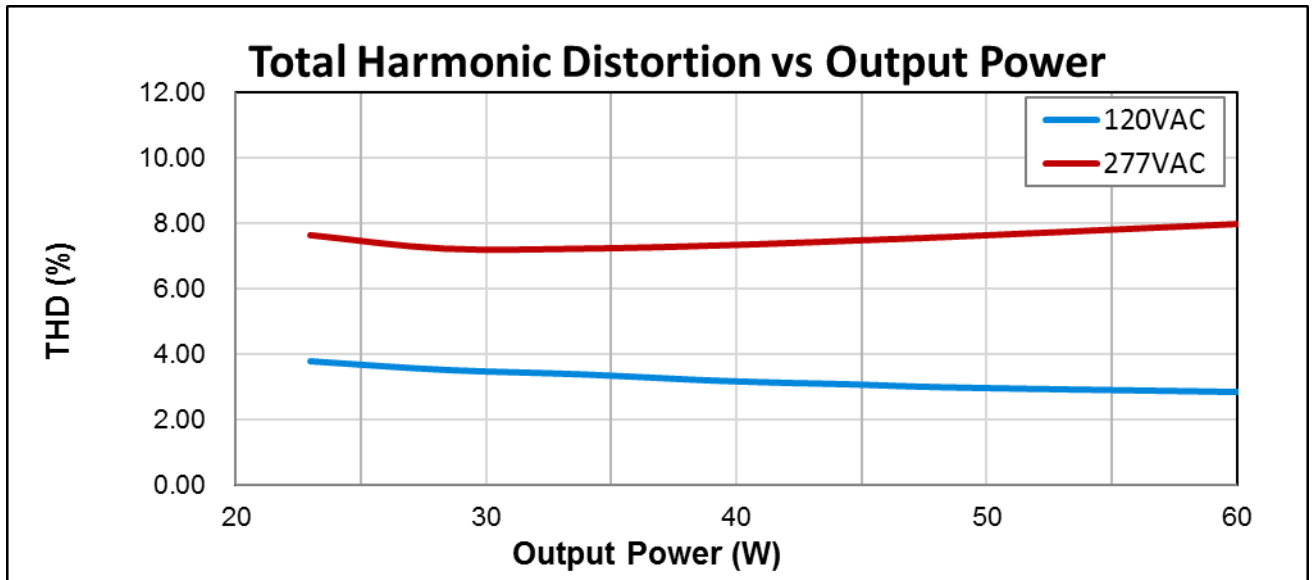

Output power based on maximum rated output current and varying load voltages.



Application and operation performance specification information subject to change without notification.



| Transient Protection | | |
|---|-------------------------|-------------------------------|
| Transient | Differential Mode (L-N) | Common Mode (L-G, N-G, L&N-G) |
| IEEE C62.41 100kHz Ring Wave (200A maximum) | > 2.5kV | > 2.5kV |

| Isolation | | | |
|-----------|-----------|-----------|-----------|
| Isolation | Input | Output | Enclosure |
| Input | - | 2xU + 1kV | 2xU + 1kV |
| Output | 2xU + 1kV | - | 500V |
| Enclosure | 2xU + 1kV | 500V | - |

U = Max Input Voltage

Driver Lifetime vs. Driver Case Temperature

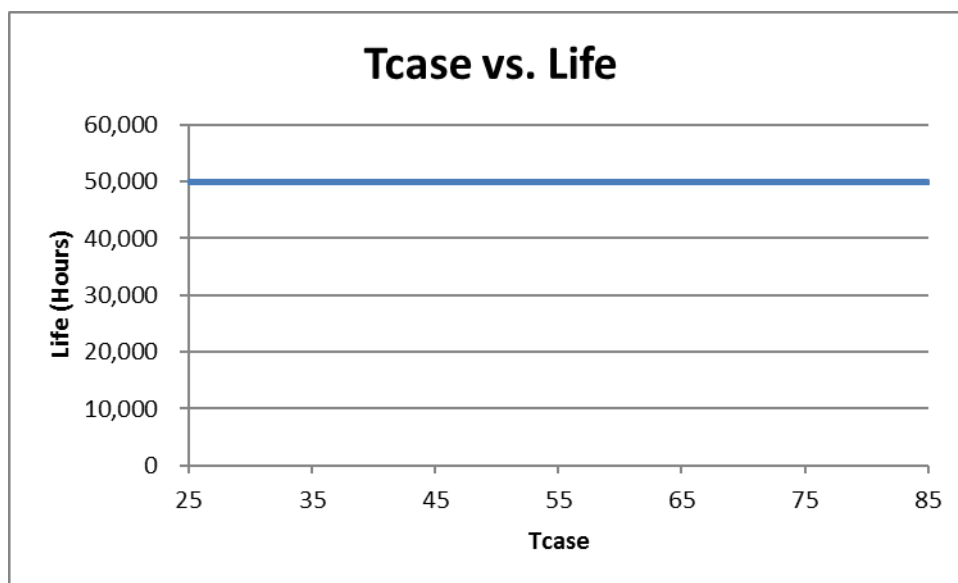

The Data curve provided predicts the LED Driver life based on the case temperature measured at the Tc location identified on the label or specification sheet. The Telecordia SR-332 standard is used to generate the prediction curves.



Application and operation performance specification information subject to change without notification.



Dimensional Diagram:

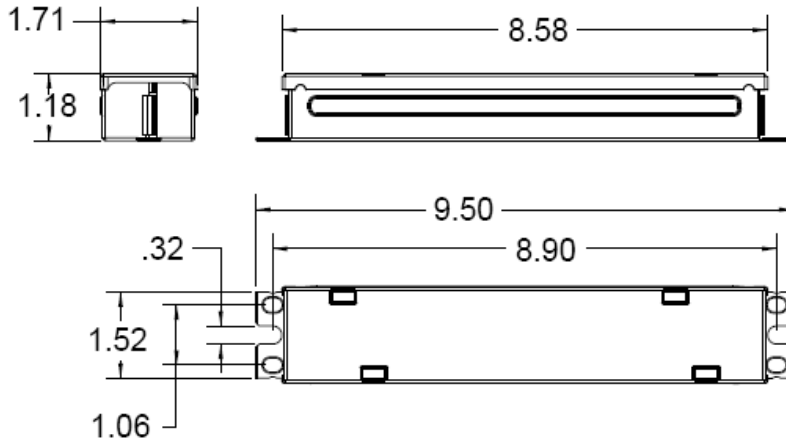

Tc Location:

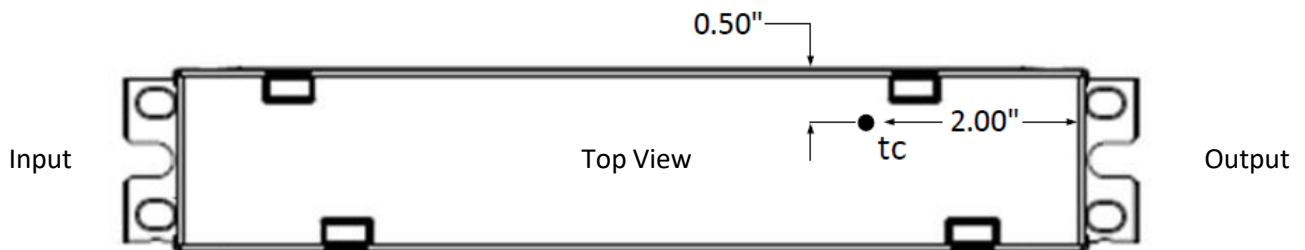

Application and operation performance specification information subject to change without notification.



(Recognized Component Driver – Referred to when used in a Light Fixture)

Conditions of Acceptability -

1. The drivers shall be installed in compliance with the applicable requirements of the end-product standard for, mounting, spacing, casualty and segregation
2. The maximum available output parameters were within the maximum allowable limits for Class 2, inherently limited as specified in the UL1310 standard for Class 2 Power Units and also in accordance with the Canadian safety standard CSA C22.2 No. 223.
3. The Driver is suitable for use in “DAMP” or “DRY” locations.
4. The driver was evaluated for use in a 57.7°C elevated ambient and the maximum case temperature at (Tc) location – as identified in Illustration-4 - should not exceed 80°C when the driver is installed in the end-use application.
5. The leakage current test was performed in accordance with the UL1310 standard while the driver was connected to a 120 V and also while connected to a 240 V source of supply and the maximum measured leakage current was 0.25 mA.
6. The primary (Black-White) and the output (Red-Black) connection wires of the driver are R/C (AVLV2/AVLV8), 18 AWG, 90 C. The suitability of the leads shall be determined in the end-use application.
7. The input and output leads were not subjected to the strain relief test.

AND:

(Recognized Component Sign Accessory – Referred to when used in an Electric Sign)

Condition of Acceptability – When installed in the end-use equipment, consideration shall be given to the following:

1. The power supply shall be installed in compliance with the applicable requirements of the end-product standard for, mounting, spacing, casualty and segregation.
2. The maximum available output parameters were within the maximum allowable limits for Class 2, inherently limited as specified in the UL 1310, Standard for Class 2 Power Units and also in accordance with the Canadian Safety Standard CSA C22.2 No. 223.
3. The power supply was submitted and tested for a maximum manufacturer’s recommended Tc location, should not exceed 80°C, in ambient of 57°C. If adjacent LED power supplies are spaced closer than 1 in. end to end or 4 in. side to side a temperature test shall be conducted in the end use product.
4. Power Supply is intended for use in indoor Dry and Damp location only.
5. In the end product, power supply spacing to other heat producing components shall be minimum 2 inches spacing to sidewalls, and minimum 2 inches spacing to top of enclosure. Adjacent power supplies shall be spaced at least 1 in. end to end and 4 in. in any other direction.
6. The input and output leads were not subjected to the strain relief test.
7. The primary (Black-White) and the output (Red-Black) connection wires of the power supply are R/C (AVLV2/AVLV8), 18 AWG, 90°C. The suitability of the leads shall be determined in the end-use application.

FCC Statement: This device complies with part 15 of the FCC Rules. Operation is subject to the following two conditions: (1) This device may not cause harmful interference, and (2) this device must accept any interference received, including interference that may cause undesired operation.

Warranty:

Universal Lighting Technologies warrants to the purchaser that each power supply will be free from defects in material or workmanship for a period of 5 years from the date of manufacture when properly installed per instructions and under normal operating conditions of use. Call 1-800-225-5278 for technical assistance.



Application and operation performance specification information subject to change without notification.